

MULTI-LIP CARTRIDGE SEAL

For Challenging Applications

Viscous substances like syrups, tars, oils, resins, and glues can often cause problems for regular mechanical seals. Until now, simple lip seal designs have been the preferred choice for dealing with these substances, which are far thicker than what most mechanical seals are designed to handle. Flexaseal's MLC3 multi-lip cartridge seal combines the best of both technologies, bringing you a game-changing solution.

Our MLC3 cartridge seal gets the job done more effectively, sealing across a broad range of speeds with longer life in service compared to other products. As an added benefit, the MLC3 requires virtually no seal support system, saving you time and effort.

- Non-clogging, proprietary engineered lip seals resist shearing and provide a reliable seal over the integrated hard-coated shaft sleeve.
- Anti-rotation rings in the lip seals provide exceptional static sealing ability.
- Energized O-ring maintains a seal and prevents leakage with viscosity changes in the process.
- Proprietary lip seal material, PTFE-ML, is not only suited for aggressive chemicals and viscous abrasives, but also complies with GMP, FDA, and EU standards.
- Easy to install cartridge design for quick and simple fit-ups.
- Field repairs are simplified with readily-available spare parts kits.

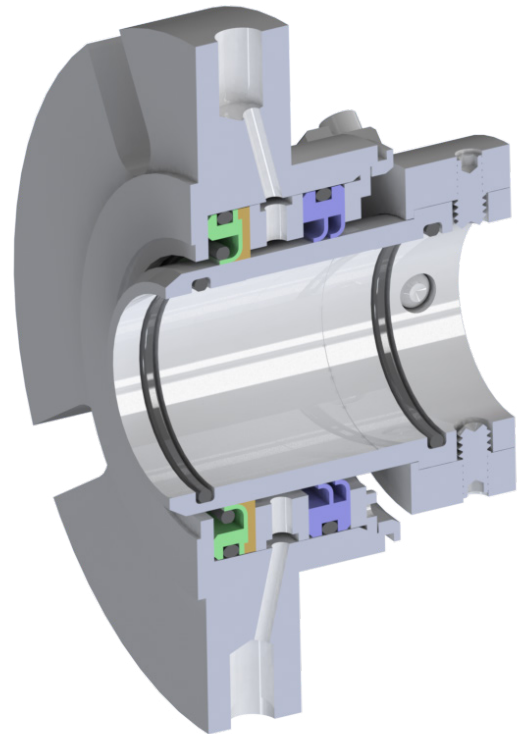

THE FLEXASEAL ADVANTAGE

OUR PTFE-ML LIP SEAL CAN TOLERATE:

- Axial Movement:** ±.125"
- Max. Runout:** ±.020" TIR (typical)
±.025" TIR (low speeds)
- Vacuum:** 25mm Hg

MATERIALS OF CONSTRUCTION

Lip Seals	PTFE-ML proprietary compound
Sleeve	Hard Coated 316 SS Sintered Silicon Carbide upon request
Elastomers	FKM standard Other materials upon request
Lantern Ring	PTFE
Metallurgy	316 SS
Also available	<ul style="list-style-type: none"> • FDA-approved materials of construction • Energized O-ring or garter spring options

OPERATING PARAMETERS

Viscosities	up to 500,000 cps
Process Pressures	up to 300 psig (20.7 bar)
Temperatures with environmental control	-100° to 450°F (-73.3 to -267.7°C)
Surface Speeds	Dry running: 3000 fpm (15.24 m/s) With environment control: 5000 fpm (25.4 m/s)

Maximum viscosity/temperatures/speed/pressure indicates operating extremes independently and does not imply the seal will function at these extremes at the same time.

Single Lip Seal With Anti-Rotation Ring And Integrated Back Up Ring

Energized front lip prevents leakage when transitioning between high viscosity and high fluidity processes. Anti-rotation rings statically seal even under normal temperature cycling. The integral back up ring provides added lip support under higher pressures and potential pressure spikes.

Energized O-Ring

Front lip tolerates lower speeds and higher shaft runout. This design increases sealing viability with certain emulsifiers and fluid viscosity transitioning such as CIP applications.

Lantern Ring

Multifunctional PTFE ring provides additional bearing support as well as even dispersion of lubricant or barrier/buffer fluid around the lip seals.

Double Lip Seal With Anti-Rotation Ring

The PTFE-ML compound is formulated with a lower coefficient of friction, which coupled with the enhanced heat dissipation leads to a lower under-lip temperatures. Lower temps = lower seal and sleeve surface wear.

Sleeve

Hard-coated stainless steel sleeve offers exceptional durability under lips with a long-lasting sealing surface. Optional solid Silicon Carbide sleeve available upon request.

316 Stainless Construction

of the drive collar and gland. Enhanced corrosion allowance as compared to 304 SS used in competitor designs.

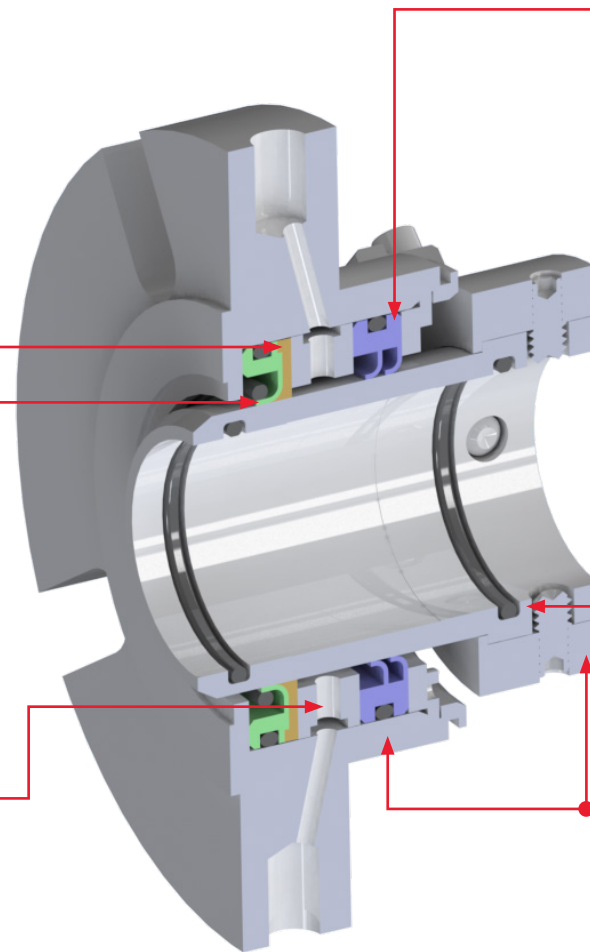

ADDITIONAL MLC3 SEAL CONFIGURATIONS

Tandem configuration with Lubricant or Purge.

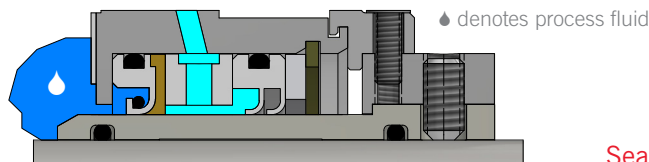

Dual Seal or Vacuum configuration with Barrier / Buffer Fluid.

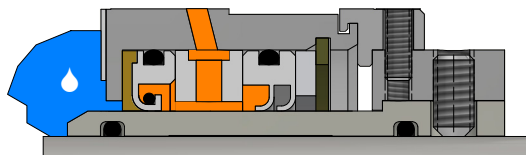

Seals can be grease packed with Magnalube®-G or Molykote™111 upon request.