

# FLEX-A-GARD

## POLYURETHANE BAR SCREEN RAKES

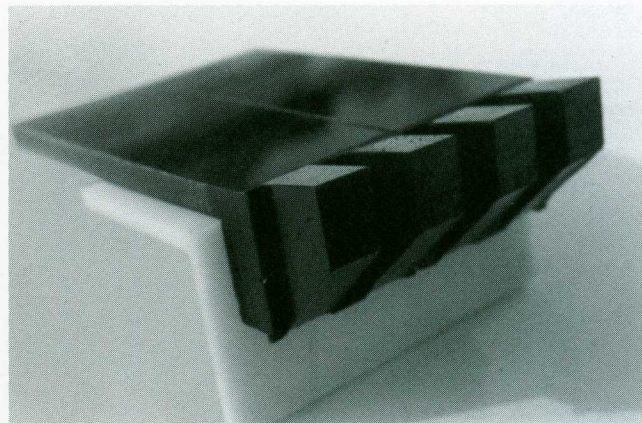
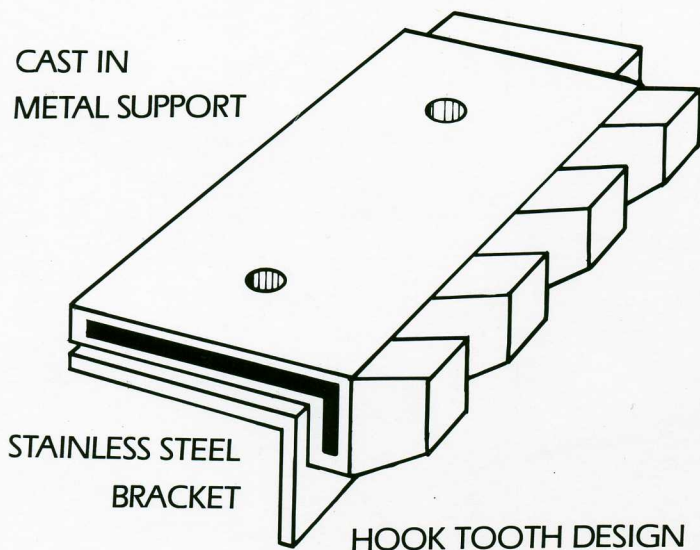

**1** Flex-A-Gard steel reinforced polyurethane bar screen rakes are designed to operate in the toughest conditions that can occur in the waste water plant. They are produced by encapsulating a metal support bar in polyurethane.

**2** Because polyurethane rakes are 2/3rds lighter than the steel rakes they replace, they are easier and faster to install. This quality makes working in the harsh environment of the bar screen less of a time consuming, back breaking chore.

**3** Reduction of the weight of the rakes also adds considerable life to the chain and sprocket system that pulls them. 2 to 3 times the life of a conventional system is not uncommon.

**4** Urethane rakes are resistant to most chemicals found in waste water. They will not rust.

**5** Rakes are available in sectional design. This makes replacement a simple task.

**6** Hooked tooth design greatly adds to the rakes ability to remove trash from the rack.

**7** Rakes can be custom designed for your application, be it front clean or back clean.

**8** With the use of polyurethane rakes you can now use non-metallic chain on your bar screen.



A Division of Flex-a-Seal, One Jackson Street, P.O. Box 184, Essex Jct. VT 05453-0184

**(800) 426-3594 FAX (802) 878-2479**

