

FLEX-A-GARD

1020 TANK RAIL

1020 Tank Rail has been specifically designed to eliminate the common problems associated with other types of rail systems such as bowing, warping and releasing. It consists of two parts, the rail and the attachment bracket.

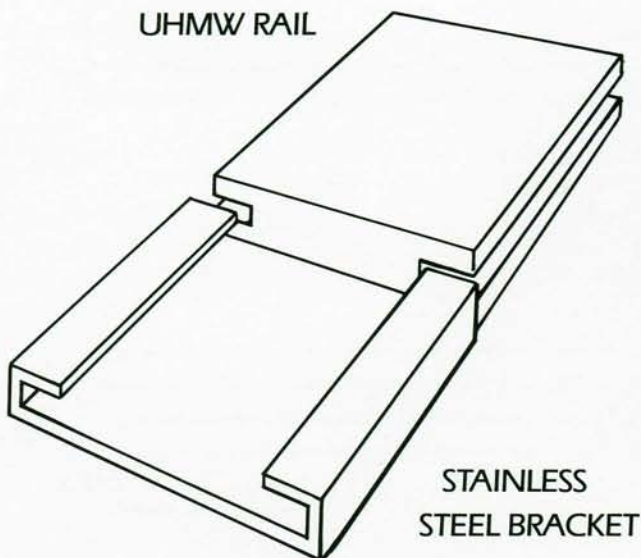

1 The bracket is a hooked channel type that allows the plastic rail to be positively attached on both sides. The bracket can be either spot welded or screwed to the existing tank rail. It can be either steel or stainless steel. The design eliminates the use of cup or weld washers and needs no plugs.

2 The rail is produced from UHMW-PE which has an abrasion resistance 5 times better than steel. Additionally UHMW-PE is $\frac{1}{8}$

the weight of steel, absorbs no water and is corrosion resistant. The rail is notched on both sides full length to allow entry into the bracket. It is held full length by the bracket and will not warp or bow.

3 1020's low coefficient of friction and low weight can reduce power needed to drive the system by 15%.



A Division of Flex-a-Seal, One Jackson Street, P.O. Box 184, Essex Jct. VT 05453-0184

(800) 426-3594 FAX (802) 878-2479

1020 TANK RAIL

Rail is produced from UHMW-PE material and is notched both sides full length to allow entry into the 1020 type bracket. Rail has no holes or plugs and presents an unbroken wear surface for wear shoes to ride against. Rail can be butted end to end and needs no gap between sections.

1020 bracket is manufactured from 300 series stainless steel. The configuration of 1020 bracket is a hooked channel type capable of retaining plastic rail on both sides, full length. Bracket must be capable of being welded or screwed to existing tank rail.

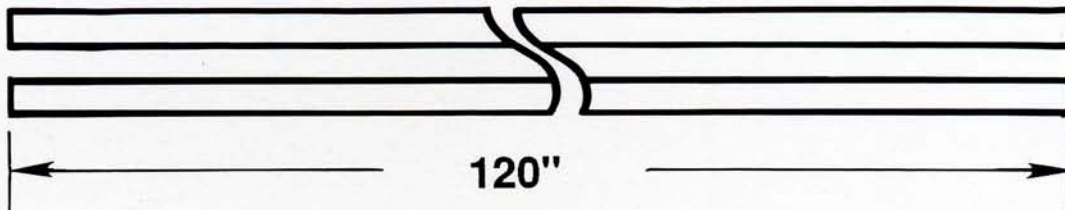
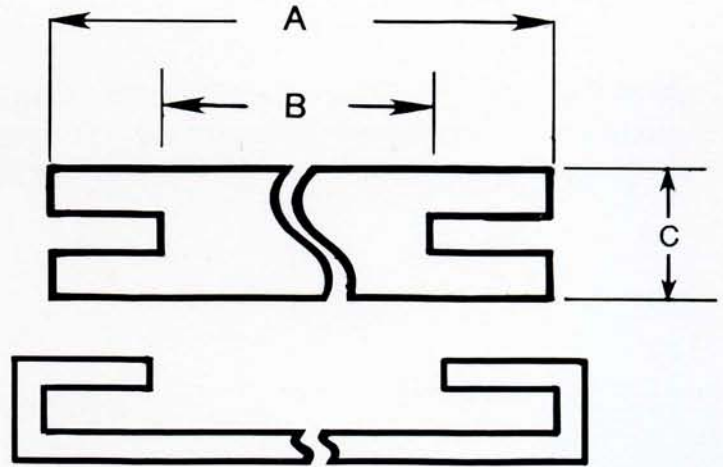

1020 Rail is available in many sizes for various applications and can be constructed to suit your needs. For more common sizes, please order from the chart below.

SIZE	A	B	C	PT.NO.	STEEL	SS
2.000"	2.000	1.200	.500	1020-200	S	SS
2.375"	2.437	1.637	.500	1020-237	S	SS
3.000"	3.000	2.200	.500	1020-300	S	SS
3.500"	3.500	2.700	.500	1020-350	S	SS
4.000"	4.000	3.200	.500	1020-400	S	SS
5.000"	5.000	4.200	.500	1020-500	S	SS



A Division of Flex-a-Seal, One Jackson Street, P.O. Box 184, Essex Jct. VT 05453-0184

(800) 426-3594 FAX (802) 878-2479